

Gosafe[®]

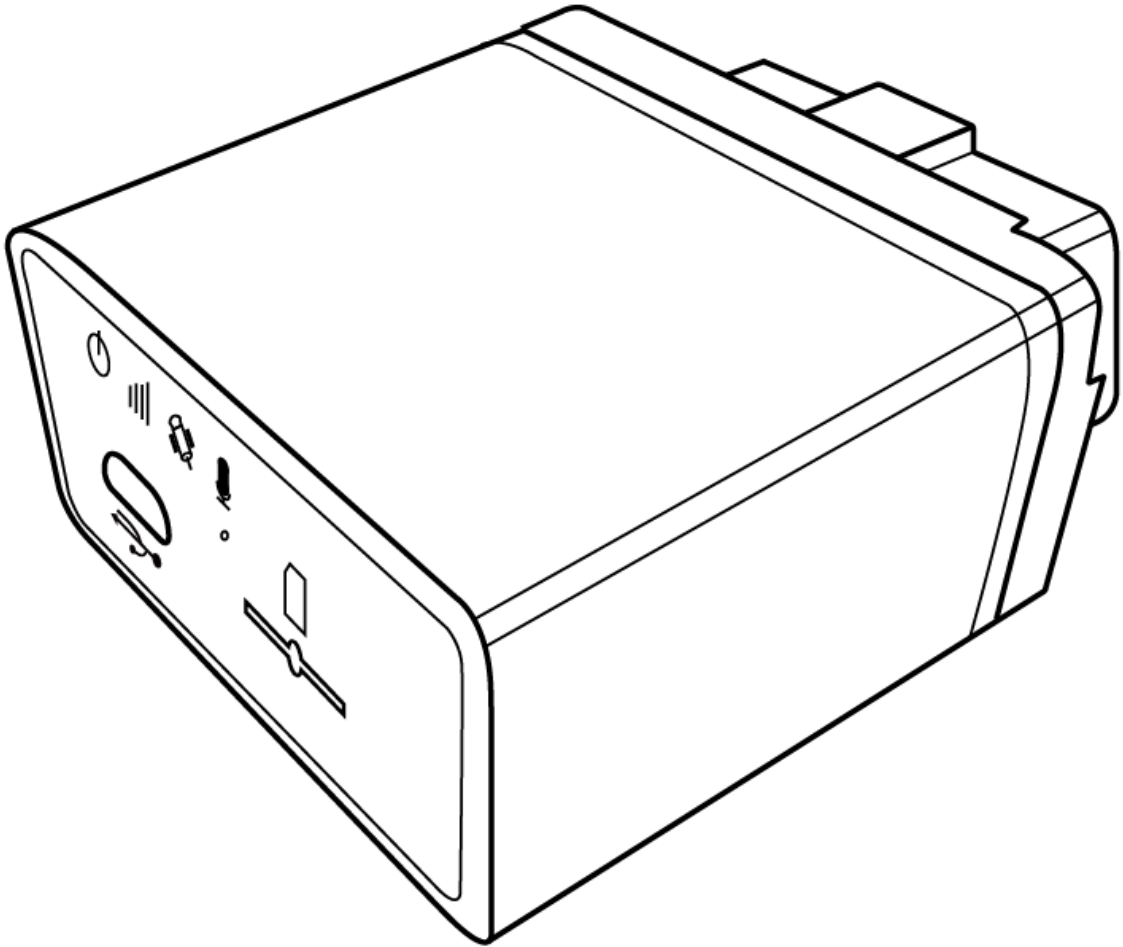

G79/G77 User Manual v1.1

ATTENTION

- ◆ Do not disassemble the device. Do not touch before unplugging the power supply if the device is damaged, the power supply cables are not isolated or the isolation is damaged.
- ◆ All wireless data transferring devices produce interference that may affect other devices which are placed nearby.
- ◆ The device may be connected only by qualified individuals.
- ◆ The device must be firmly fastened in the predefined location.
- ◆ The device is susceptible to water and humidity.

INSTRUCTIONS OF SAFETY

- ◆ This chapter contains information on how to operate “G79/G77” safely.
- ◆ BY following these requirements and recommendations you will avoid dangerous situations. You must read these instructions carefully and follow the strictly before operating the device!
- ◆ The device uses a 8V-32V DC power supply. The nominal voltage is 12V DC. It is advised to transport the device in an impact-proof package.
- ◆ Before usage, the device should be placed so that its LED indicators are visible, which show what status of operation the device is in.
- ◆ When connecting the connection cables to the vehicle, the appropriate jumpers of the power supply of the vehicle should be disconnected.
- ◆ Before dismounting the device from the vehicle, the connection must be disconnected.

LEGAL NOTICE

- ◆ Copyright © 2014 Gosafe.
- ◆ All rights reserved. Reproduction, transfer, distribution or storage of part or all of the contents in this document in any form without the prior written permission of Gosafe is prohibited.
- ◆ Other products and company names mentioned herein may be trademarks or trade names of their respective owners.

INTRODUCTION

- ◆ With OBDII interface, accurate GPS location performance, a robust programmable rules engine, 3 axis accelerometer for measuring driver behavior and vehicle impacts, geo-fencing, messaging and much more, the G79/G77 is designed for powerful solution deployment.
- ◆ The G79/G77 is powered by over-the-air device management and maintenance system, (Programming, Updates, and Logistics System). FOTA (Firmware update over the air), GSM Jamming detection and 156 hardware based geo-fences makes this the perfect choice for superior safety and security of your vehicle.

Conents

1. Packing list	4
2. Specifications	4
3. Features and event	5
4. Overview.....	6
4.1. Front	6
4.2. Rear	6
5. Installation	7
5.1. SIM card	7
5.2. Sensor calibration	7
6. LED behavior.....	8
6.1. GSM LED: Green.....	8
6.2. GPS LED: Yellow.....	8
6.3. Power LED: Red	8
7. User command	9
8. Message sample	13

1. Packing list

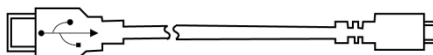
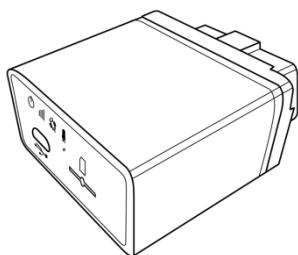

2. Specifications

Physical	Dimension	58.5(L)*50(W)*27(H)mm	
	Weight	~60g (With battery)	
Environment	Operating temperature	-40°C to +80°C (without backup battery) -10°C to +50°C (with backup battery)	
Interface	*CAN	CAN_H & CAN_L	
	*ISO	ISO_K & ISO_L	
	*J1850	J1850+ & J1850-	
	VCC	1 PIN	
	GND	2 PIN	
USB	Mini USB	2.0	
CPU	ARM	STM32F103	
LED indicator	3 LED indicators	GSM & GPS & POWER	
Power supply	External	DC 8 to 32V	
	Backup battery	Type	Rechargeable, Li-Po 3.7V, 250mAh
Power consumption	Standby: 33mA@12V, Operating: 130mA@12V		
GSM/GPRS	Antenna	Built-In	
	Model	Cinterion BGS2-W	
		Quad band: 850/900/1800/1900MHz	
		Multiple-slot Class 8 (dual band)/10 (quad band) GPRS class 10/Station class B	
		TCP/IP over PPP	
SIM card	1.8V & 3.3V		
GPS	Internal antenna	25*25mm with amplifier	
	External antenna	Not supported	
	Model	u-Blox NEO 6M	
	Channel	50 Parallel Channels	
	Accuracy	Autonomous<2.5M	
	Sensitivity	-162dBm	
Sensor	Accelerate sensor	Built-In, 3 axis	
Flash storage	16Mbits	Built-In	

*Only for G79/G79W

3. Features and event

◆ **Features**

- ✓ OBDII interface
- ✓ Built-in 3 axis acceleration sensor
- ✓ A-GPS supported
- ✓ GSM jamming detection
- ✓ Private activity hour mode
- ✓ Multiple user profiles switching automatically on preset conditions
- ✓ Dynamic report interval on preset conditions
- ✓ Fixed distance and fixed angle cornering report
- ✓ Flexible report packet size on demand
- ✓ Various single events report and combination event report supported
- ✓ Hardware based Geo-fence supported up to 156
- ✓ OTA firmware upgrade supported

◆ **Supported event list**

Tracker is capable to report below specific events instantly via GPRS/SMS channel according to setting.

#	Event name	Status change event	
1.	Tow	Quit tow	Enter tow
2.	Idle	Quit idle	Enter idle
3.	Parking	Quit parking	Enter parking
4.	Speed	Enter preset speed range	Leave preset speed range
5.	GSM jamming	Quit jamming	Enter jamming
6.	Geo fence		Yes
7.	GPS acquisition		Yes
8.	Health report		Yes
9.	Harsh brake		Yes
10.	Harsh acceleration		Yes
11.	Harsh left cornering		Yes
12.	Harsh right cornering		Yes
13.	Collision		Yes
14.	Turn over		Yes
15.	External power supply		Under preset voltage threshold
16.	Backup battery		Under preset voltage threshold
17.	*Wireless immobilizer status	Connected	Disconnected
18.	*Tag status	Tag absent	Tag present
19.	*Pair event		Yes
20.	*Tag low voltage	No	Yes
21.	OBDII DTC event	No	Yes
22.	Engine over revving	No	Yes
23.	Engine over heat	No	Yes
24.	Maintenance mileage notice	No	Yes
25.	Engine oil changing notice	No	Yes
26.	Tire changing notice	No	Yes
27.	Engine status	ON to OFF	OFF to ON
28.	SIM card balance notice		Yes

Note: Above events by default are disabled please enable them by configuration tool if necessary or contact your distributor for further information regarding this topic.

4. Overview

◆ 4.1. Front

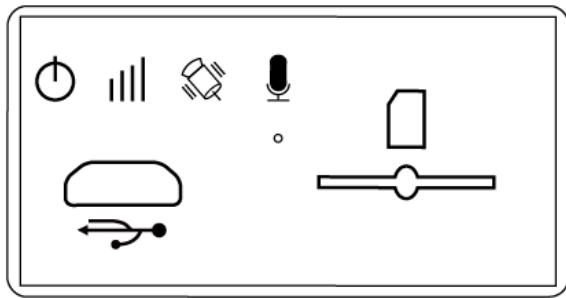

- ✓ Power LED indicator
- ✓ GSM status LED indicator
- ✓ GPS status LED indicator
- ✓ Microphone
- ✓ Mini USB 2.0 interface
- ✓ SIM card holder

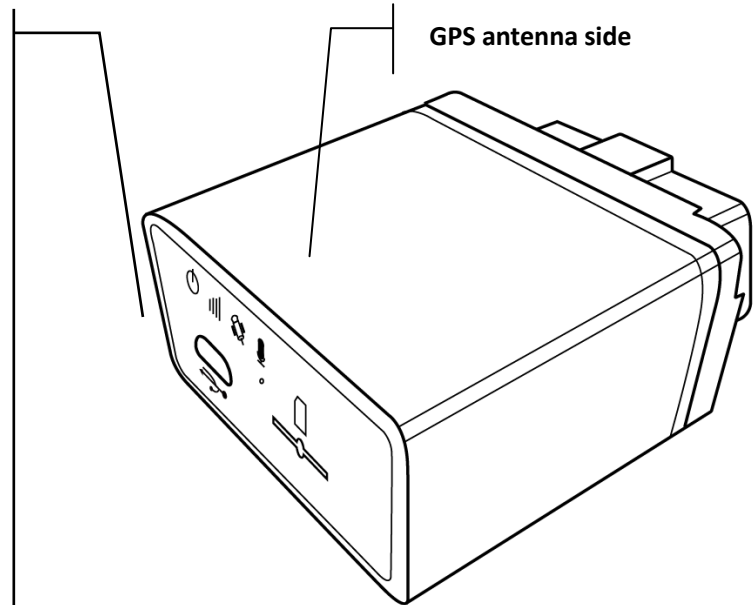

◆ 4.2. Rear

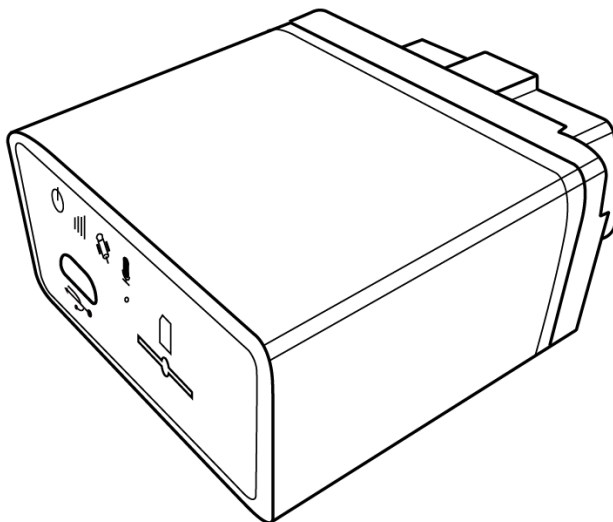

ODBII interface, protocol supported such as:

- ✓ SAE J1850-PWM
- ✓ SAE J1850-VPW
- ✓ ISO 9141-2
- ✓ ISO 14230-4
- ✓ ISO 14230-4
- ✓ ISO 15765-4
- ✓ SAE J1939

And so on

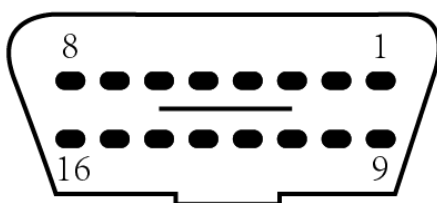

- PIN5: Signal Ground
- PIN4: Chassis Ground
- PIN6: CAN High (J-2284)
- PIN7: ISO 9141-2 K Line
- PIN14: CAN Low (J-2284)
- PIN10: J1850 Bus-
- PIN2: J1850 Bus+
- PIN15: ISO 9141-2 L Line
- PIN16: Battery power

5. Installation

◆ 5.1. SIM card

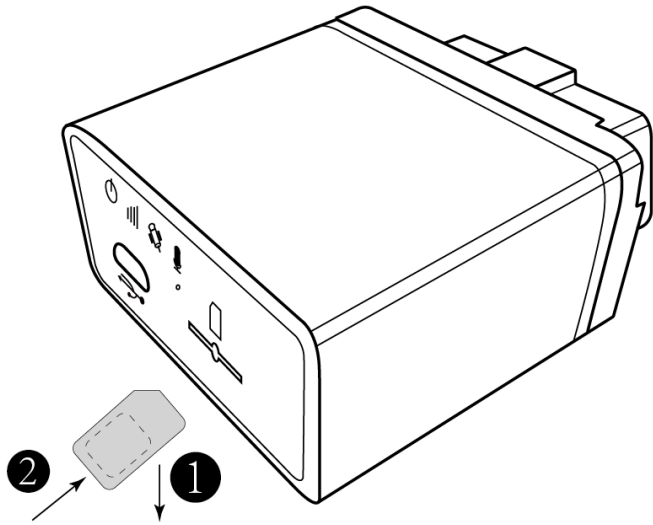

Step1:

Metal part of SIM card facing down.

Step2:

Insert and push SIM card to the button of SIM holder to lock it firmly.

◆ 5.2. Sensor calibration

This procedure is important for proper “harsh behavior” detection.

1. Locate OBDII interface around steering wheel, tracker will make a sound of “bi” when plug in.

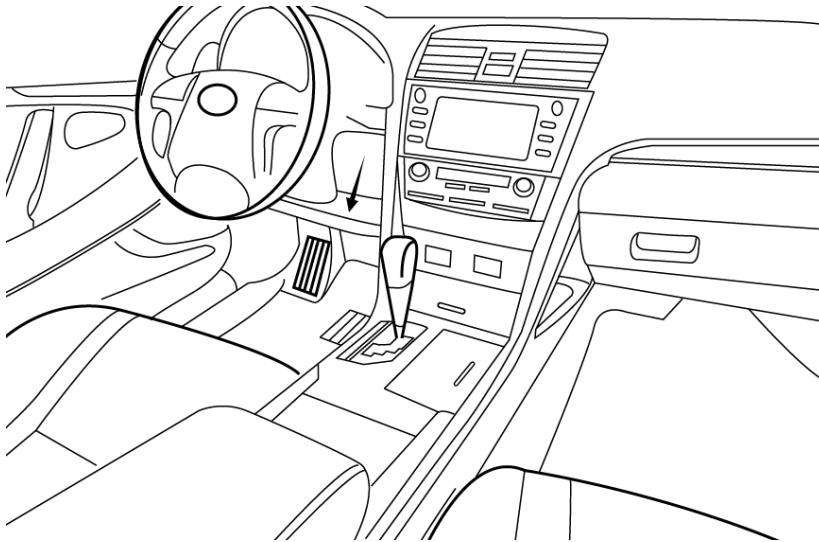

2. Please do not start the car at the beginning and keep still as possible
3. Wait about 20 seconds.
4. Tracker will make sound of “bi” 3 times which indicating “static calibration” finished.

Note: For each external power cycle tracker will restart calibration procedure.

6. LED behavior

◆ 6.1. GSM LED: Green

Server socket connected: Flash once quickly every 3 seconds

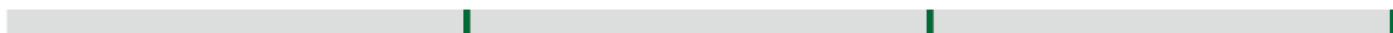

GSM network registered: Flash twice quickly in a row every 3 seconds

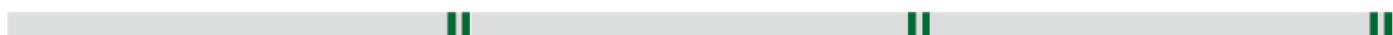

GSM network unregistered: Flash 3 times quickly in a row every 3 seconds



SIM card error: Flash 4 times quickly in a row every 3 seconds



GSM module OFF: Never flash

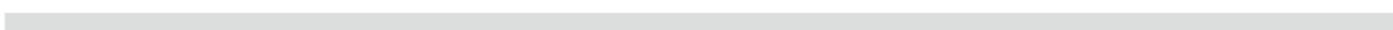

◆ 6.2. GPS LED: Yellow

GPS fixed: Flash once quickly every 3 seconds



GPS unfixed: Flash twice quickly in a row every 3 seconds



GPS communication error: Flash 3 times quickly in a row every 3 seconds



GSM module OFF: Never flash



◆ 6.3. Power LED: Red

Using external power supply: Flash once quickly every 3 seconds



Using backup battery: Flash twice quickly in a row every 3 seconds



Backup battery low voltage: Flash 3 times quickly in a row every 3 seconds



7. User command

◆ Command UNO0

This command is to set user phone number#1 that has authority to interact with tracker.

Example:

Phone number: 13800138000, country code: +86

1234,UNO0;+8613800138000	Tracker
User SMS	G79 V1.00 UNO0:+8613800138000 EXT_PWR=11.94V BAT=3.90V #1

◆ Command UNO1

This command is to set user phone number#2 that has authority to interact with tracker.

Example:

Phone number: 13800138000, country code: +86

1234,UNO1;+8613800138000	Tracker
User SMS	G79 V1.00 UNO1:+8613800138000 EXT_PWR=11.94V BAT=3.90V #1

◆ Command UPW0

This command is to change the default password 1234 for user phone number#1, 4 digits fixed.

1234,UPW0;5678	Tracker
User SMS	G79 V1.00 UPW0:5678 EXT_PWR=11.94V BAT=3.90V #2

◆ Command UPW1

This command is to change the default password 1234 for user phone number#2, 4 digits fixed.

1234,UPW1;5678	Tracker
User SMS	G79 V1.00 UPW1:5678 EXT_PWR=11.94V BAT=3.90V #2

◆ Command MEI

This command is to query GSM module IMEI of tracker, aka device ID.

1234,MEI	Tracker
-----------------	---------

User SMS

G79 V1.00
MEI:351535053999389
EXT_PWR=11.94V
BAT=3.90V
#3

◆ **Command BLS**

This command is to set low balance notification/query current balance of tracker SIM card.

1234,BLS;*125	Tracker
User SMS	G79 V1.00 BLS:*125 EXT_PWR=11.94V BAT=3.90V #4

◆ **Command PRQ**

This command is to query current position of tracker.

1234,PRQ	Tracker
User SMS	G79 V1.00 LTM 2013-06-06 14:17:12 http://maps.google.com/maps?q=23.164374,113.428576&t=m&z=16 EXT_PWR=11.94V BAT=3.90V #5

Note: Position information in message may vary depending on setting/current status.

◆ **Command MGR**

This command is to check current accumulation mileage of tracker, unit is meter.

1234,MGR	Tracker
User SMS	G79 V1.00 MGR:100000 EXT_PWR=11.94V BAT=3.90V #6

◆ **Command CID**

This command is to check CCID of tracker SIM card.

1234,CID	Tracker
User SMS	G79 V1.00 CID:89860090191149028638 EXT_PWR=11.94V BAT=3.90V #7

◆ ***Command IMM**

This command is to force immobilizing vehicle via wireless immobilizer.

1234,IMM;1;0;0	Tracker	Remark
User SMS	G79 V1.00 IMM:1;0;0 EXT_PWR=11.94V BAT=3.90V #8	IMM;0;0;0 is command to restore from immobilizing.

Note: This command is for G79W only.

◆ **Command CAL**

This command is to ask tracker to call specific phone number, tracker will call back after receiving command.

1234,CAL;+8613800138000	Tracker
User SMS	G79 V1.00 CAL:+8613800138000 EXT_PWR=11.94V BAT=3.90V #9

◆ **Command AGN**

This command is to set volume gain of microphone.

1234,AGN;7;0	Tracker	Remark
User SMS	G79 V1.00 AGN:7;0 EXT_PWR=11.94V BAT=3.90V #9	AGN;<Parameter1>;<Parameter2> <Parameter1>: Microphone gain Range "0" to "7", bigger value is louder volume. <Parameter2>: Invalid

◆ **Command OBS**

This command is to query current OBDII connectivity status.

1234,OBS	Tracker	Remark
User SMS	G79 V1.00 OBS:1;0 EXT_PWR=11.94V BAT=3.90V #10	OBS:<Paramter1>;<Paramter2> <Parameter1>:Connection status "0" OBDII protocol is not connected. "1" OBDII protocol is connected. <Parameter2>:Specific protocol "0" Automatic "1" SAE J1850 PWM (41.6 kbaud) "2" SAE J1850 VPW (10.4 kbaud) "3" ISO 9141-2 (5 baud init, 10.4 kbaud) "4" ISO 14230-4 KWP (5 baud init, 10.4 kbaud) "5" ISO 14230-4 KWP (fast init, 10.4 kbaud) "6" ISO 15765-4 CAN (11 bit ID, 500 kbaud) "7" ISO 15765-4 CAN (29 bit ID, 500 kbaud) "8" ISO 15765-4 CAN (11 bit ID, 250 kbaud)

◆ Command VER

This command is to query current hardware and firmware version of tracker.

1234,PRQ	Tracker	Remark
User SMS	G79 V1.00 VER:V1.02-US;V1.00 EXT_PWR=11.94V BAT=3.90V #10	VER:<Hardware version>;<Firmware version>

◆ Command FWU

This command is to activate OTA firmware upgrade via GPRS.

1234,FWU	Tracker
User SMS	G79 V1.00 FWU EXT_PWR=11.94V BAT=3.90V #10

The OTA upgrade process may cost around 10 minutes and there is a confirm message for it.

	Tracker
User SMS	G79 V1.10 Upgrade Success! EXT_PWR=11.94V BAT=3.90V #11

8. Message sample

Content of message	Explanation
G79 V1.00	Device name/Firmware version
LTM 2013-06-06 14:17:12	Date/Time
http://maps.google.com/maps?q=%n(,%e&t=m&z=16	Google map hyper link
GSM -52dBm	GSM network signal strength
EXT_PWR=12.08V	External power voltage
BAT=3.86V	Built-in battery voltage
#30	Consumed messages

Content of message	Explanation
G79 V1.00	Device name/Firmware version
LTM 2013-06-06 09:41:22	Date/Time
GPS 1.55/0.50/3/4	HDOP/ALTITUDE in meter/Fixed satellite number/Time of first fixed
N23.164302	N means north/S means south
E113.428456	E means east/W means west
SPD:0km/h 0	Speed/Heading
GSM -52dBm	GSM signal strength
EXT_PWR=12.13V	External power voltage
BAT=3.96V	Built-in battery voltage
#27	Consumed messages

Content of message	Explanation
G79 V1.00	Device name/Firmware version
LTM 2013-02-28 23:51:09	Date/Time
MCC/MNC/LAC/CID/RSSI	Base station information type
460/0/2503/962C/-53dBm	Main station, MNC/MNC/Local area code/Station ID/Signal strength
460/0/2731/40F4/-60dBm	Neighbor station 1
460/0/2703/4050/-70dBm	Neighbor station 2
GSM -58dB	GSM network signal strength
EXT_PWR=5.13V	External power voltage
BAT=4.17V	Built-in battery voltage
#20	Consumed messages

Content of message	Explanation
G79 V1.00	Device name/Firmware version
LTM 2013-06-06 14:17:12	Date/Time
http://maps.google.com/maps?q=%n(,%e&t=m&z=16	Google map hyper link
ETD:6/ACC ON	Event ID/User defined event name/Data
GSM -52dBm	GSM network signal strength
EXT_PWR=12.08V	External power voltage
BAT=3.86V	Built-in battery voltage
#301	Consumed messages